

MARK 1 PRESS WITH EASYJIG TABLES



TRACKLESS PRESS SYSTEM

- 30 tonne hydraulic press with 700 x 500mm platen
- Control panel with touch screen monitor
- Pressing area dependent on number of tables
- Fully compatible with MiTek software
- Optical and mechanical high-speed emergency stop
- Tables will set the outline of the truss within 45 seconds
- Steel tables 4.2 – 4.8 x 1.93m with Halfen rails
- Independent truss ejector zones

EXPAND YOUR
CAPABILITIES

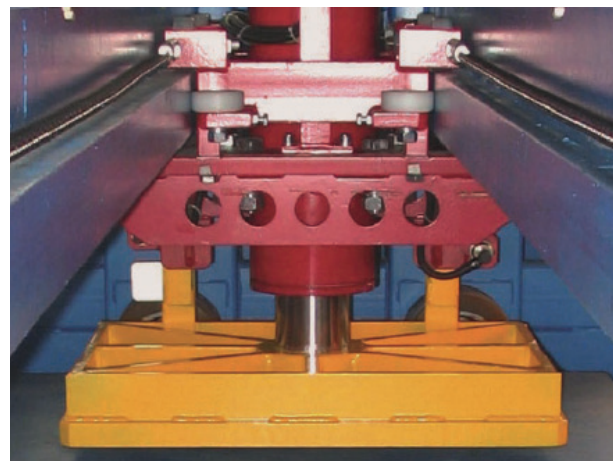

MARK 1 PRESS

With Easyjig Tables

DESCRIPTION

Rugged, versatile and dependable, the Mark I press satisfies the needs of all truss fabricators. The fast efficient single 30 tonne press head combines the strength of the Mark VII with the versatility of the Mark 8 press. It combines the best mechanical features with the latest in fabricating technology, to provide you with a state of the art press for the 21st Century. Can be used with MiTek Virtek laser system and will operate through the press.

FEATURES

- One or two parking zones
- Wi-Fi network connection
- Pucks and jig kit accessories
- Traversing ejectors Bridges for ejector gaps

PHYSICAL DATA

- Overall table width: Max 4.8m
- Overall length: Varies with table numbers
- See illustrated layout

*Drawings not to scale. Please contact us for more detailed information

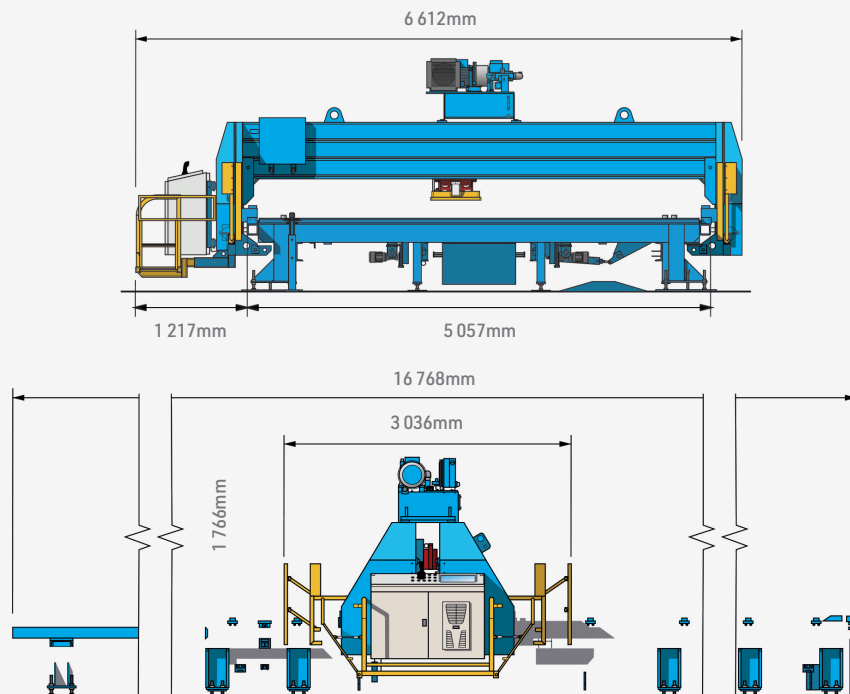

MITEK.CO.UK/MACHINERY/PRESSES-LASERS/MK1-PRESS-RANGE-2

+44-138-445-1400 | info@mittek.co.uk